

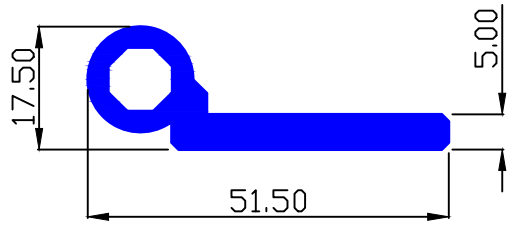

HINGES

MAAN SEC.-9428

0.849 Kg/Mtr.



MAAN SEC.-9429

0.999 Kg/Mtr.

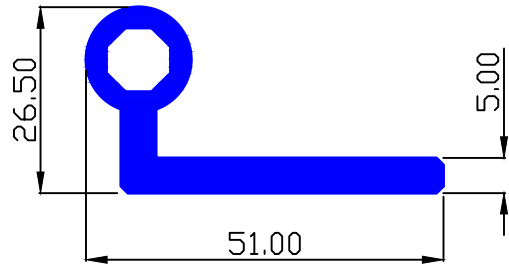

MAAN SEC.-6208

0.997 Kg/Mtr.

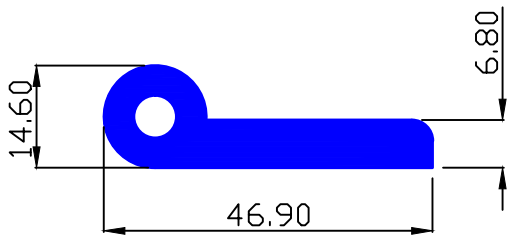

MAAN SEC.-89101

0.698 Kg/Mtr.

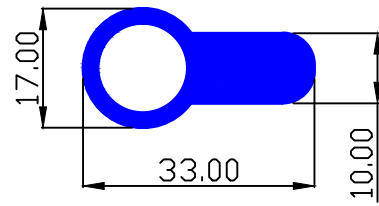

MAAN SEC.-6209

0.167 Kg/Mtr.

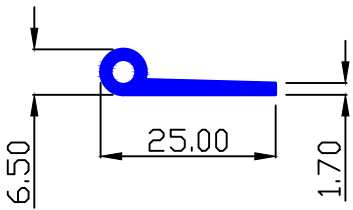

MAAN SEC.-89311

0.190 Kg/Mtr.

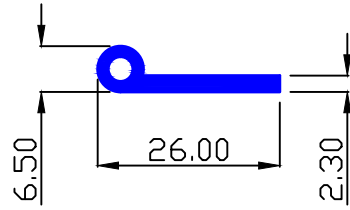

MAAN SEC.-7958

0.853 Kg/Mtr.

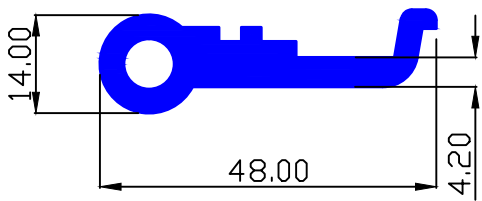



HINGES

MAAN SEC.-89812 0.230 Kg/Mtr.

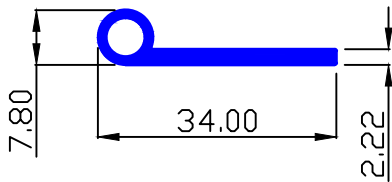

MAAN SEC.-89827 0.337 Kg/Mtr.

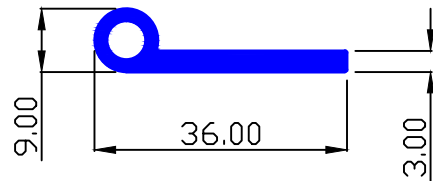

MAAN SEC.-89813 0.313 Kg/Mtr.

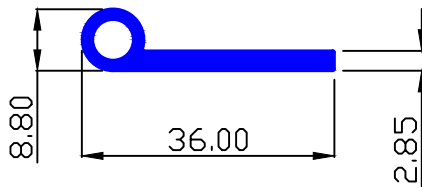

MAAN SEC.-89915 0.250 Kg/Mtr.

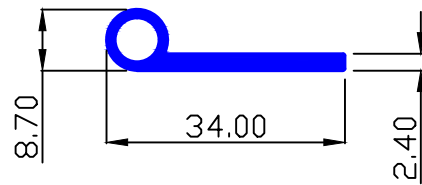

MAAN SEC.-89814 0.256 Kg/Mtr.

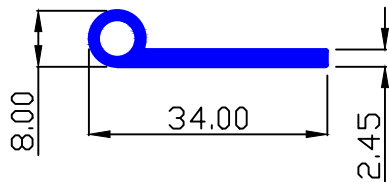

MAAN SEC.-90237 0.715 Kg/Mtr.

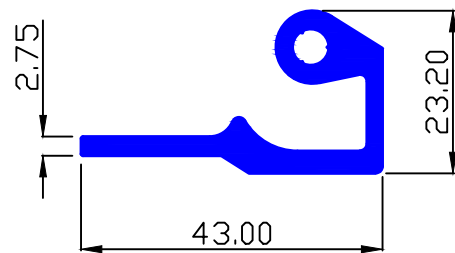

MAAN SEC.-89815 0.455 Kg/Mtr.

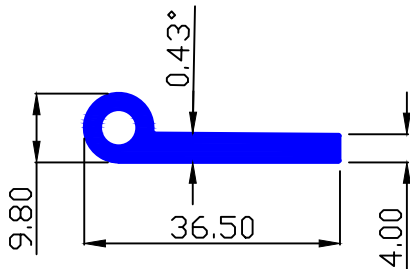

MAAN SEC.-90400 2.301 Kg/Mtr.

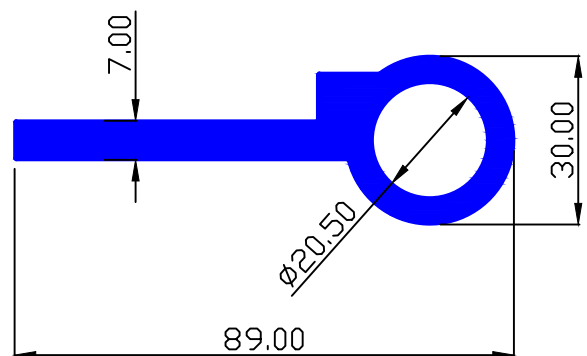

MAAN SEC.-89828 0.143 Kg/Mtr.

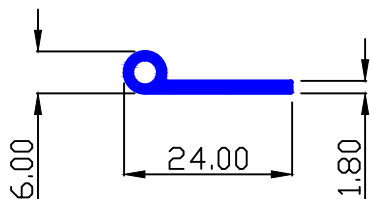



HINGES

MAAN SEC.-89804

4.689 Kg/Mtr.

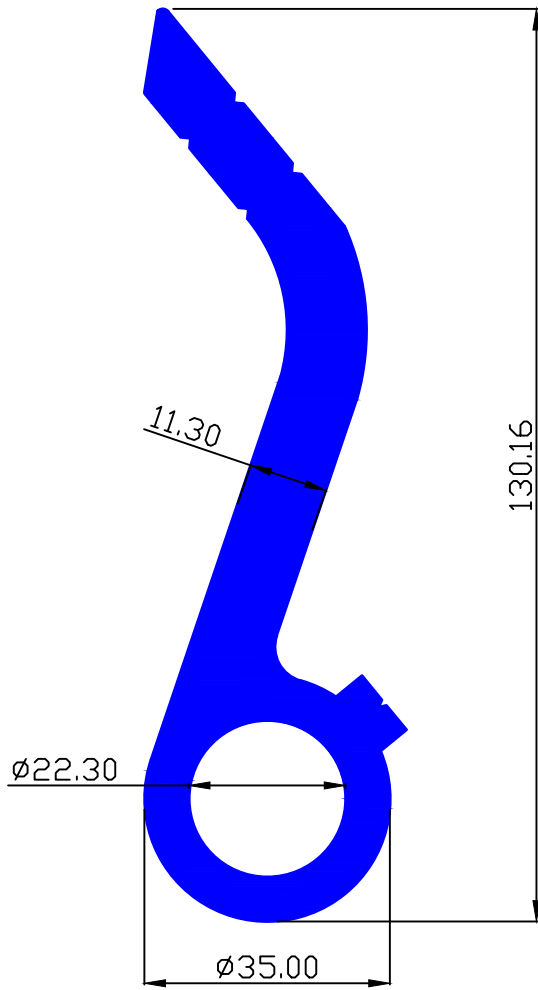

MAAN SEC.-90091

4.610 Kg/Mtr.

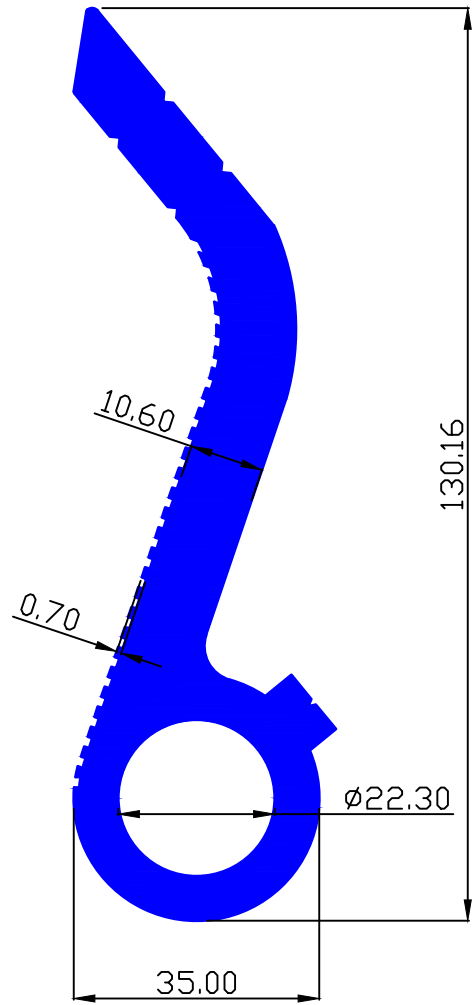

MAAN SEC.-90657

0.702 Kg/Mtr.

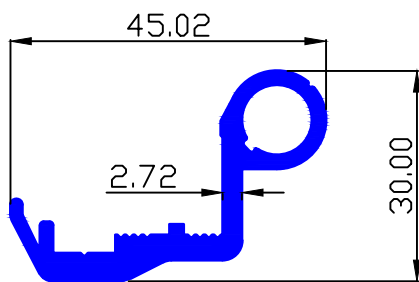

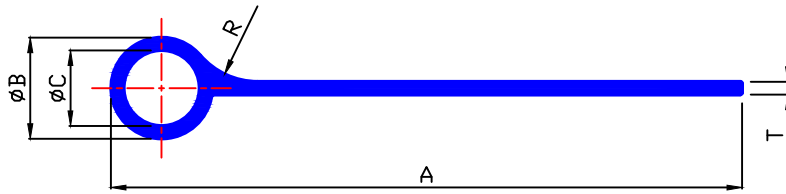

AL DROP PATTA

SEC.NO.	Amm	Bmm	Cmm	Rmm	Tmm	Kg/M	WEIGHT RANGE Kg/12'
6210-L	129.50	25.00	16.00	5.00	3.10	1.664	6.000 TO 6.400
6210-H	129.50	25.00	16.00	5.00	3.50	1.776	6.400 TO 6.600
6211	101.70	19.00	12.60	10.00	3.20	1.155	4.150 TO 4.350
6212	100.00	16.00	12.00	12.00	2.00	0.709	2.500 TO 2.700
6213	129.50	24.20	16.20	15.50	3.80	1.745	6.400 TO 6.600
6214	121.00	19.90	13.90	15.00	2.25	1.073	3.850 TO 4.050
6215	97.00	14.40	11.00	8.00	1.90	0.616	2.200 TO 2.300
6216	120.00	18.00	14.00	13.00	2.20	0.899	3.200 TO 3.300



MAAN SEC.-89690

0.538 Kg/Mtr.

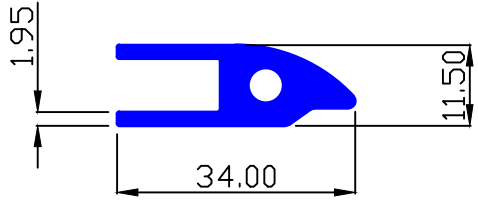

MAAN SEC.-89791

2.422 Kg/Mtr.

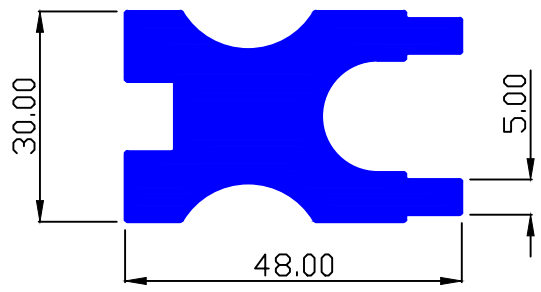

MAAN SEC.-90410

2.128 Kg/Mtr.

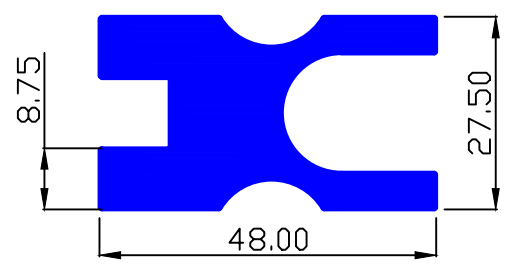



DOOR CLOSER

MAAN SEC.-6769

3.305 Kg/Mtr.

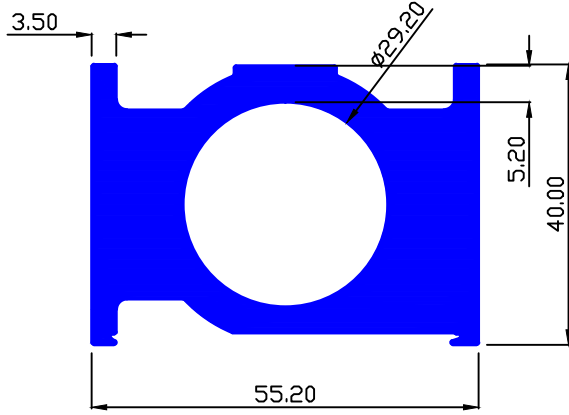

MAAN SEC.-7016

3.391 Kg/Mtr.

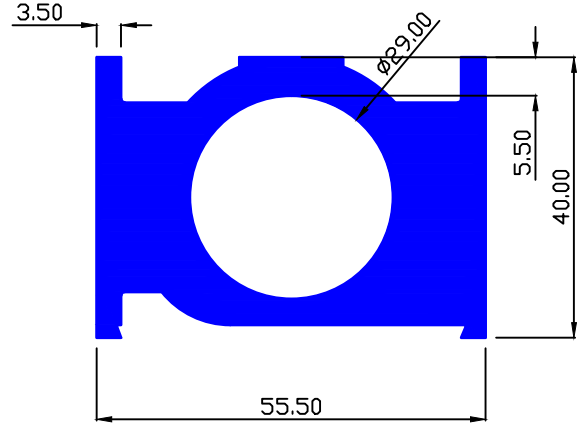

MAAN SEC.-7081

3.546 Kg/Mtr.

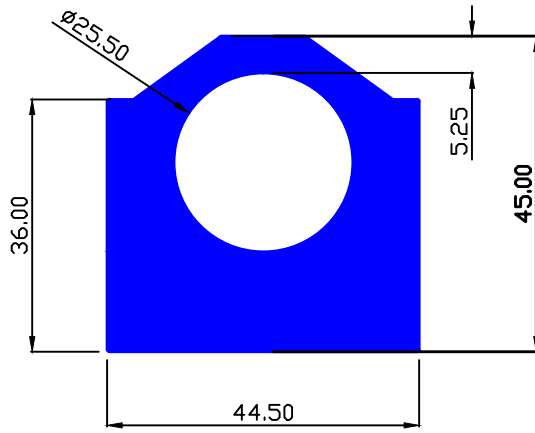

MAAN SEC.-89554

3.875 Kg/Mtr.

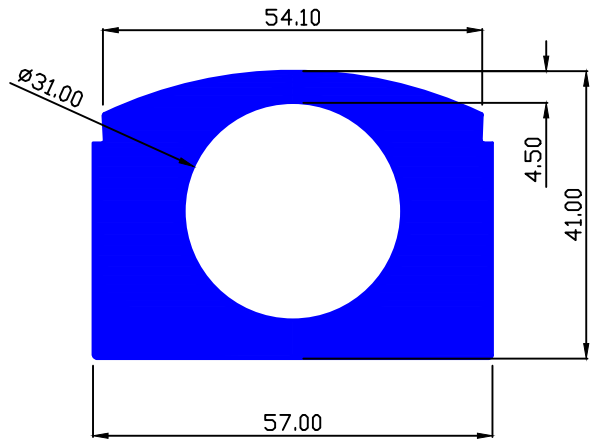

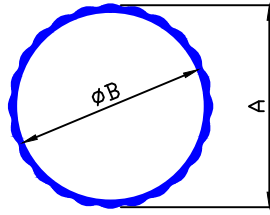

FLUTED TUBE

SEC.NO.	Amm	Bmm	KG/M	WEIGHT RANGE Kg/12'
5901	25.60	21.20	0.411	1.400 TD 1.700
5906	25.00	22.50	0.216	0.730 TD 0.840
5907	18.20	16.20	0.108	0.370 TD 0.420
5910	10.80	8.32	0.099	0.340 TD 0.390
5911	8.15	5.70	0.072	0.240 TD 0.280
5912	28.00	26.20	0.159	0.540 TD 0.620
5916	18.00	16.64	0.075	0.260 TD 0.295
5917	24.00	22.66	0.101	0.360 TD 0.400
5918	32.00	30.00	0.225	0.760 TD 0.880
5919	28.80	26.80	0.194	0.660 TD 0.760
5921	24.40	19.50	0.305	1.040 TD 1.200
5922	28.00	24.20	0.341	1.160 TD 1.330
5923	24.90	22.10	0.289	0.980 TD 1.130
5924	19.00	16.00	0.177	0.600 TD 0.700
5925	28.00	24.70	0.269	0.910 TD 1.050
5926	22.50	19.50	0.191	0.650 TD 0.750
9396	50.80	47.50	0.642	2.180 TD 2.510
9422	50.80	47.00	0.772	2.630 TD 3.020



HARD WARE

MAAN SEC.-8953

1.260 Kg/Mtr.

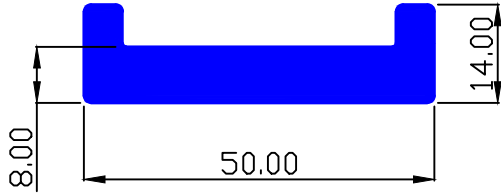

MAAN SEC.-89509

1.292 Kg/Mtr.

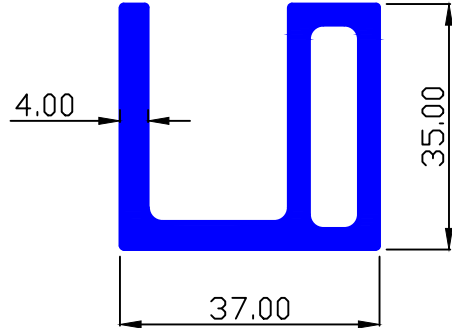

MAAN SEC.-89019

0.826 Kg/Mtr.

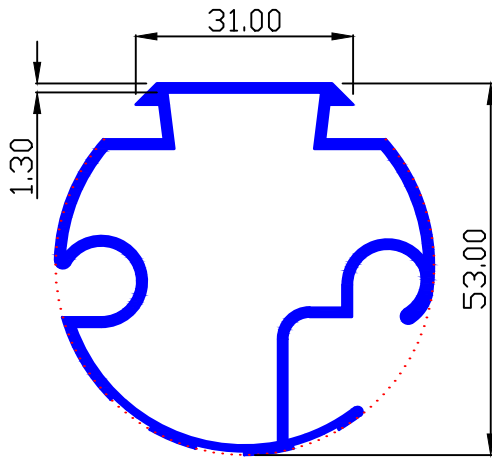

MAAN SEC.-89261

0.153 Kg/Mtr.

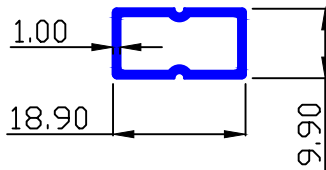

MAAN SEC.-89585

0.902 Kg/Mtr.

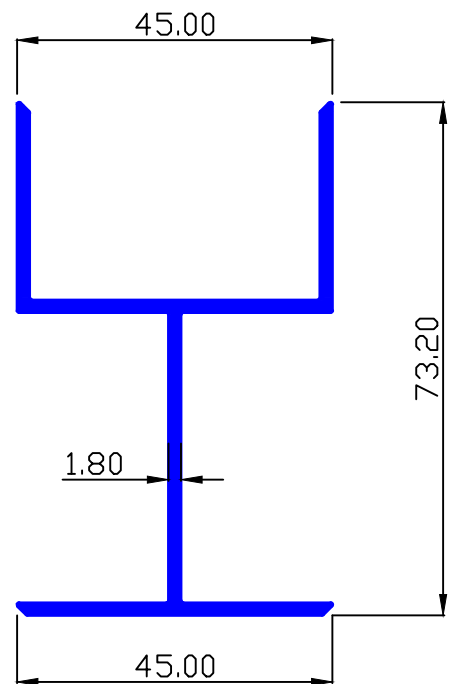

MAAN SEC.-89507

0.362 Kg/Mtr.

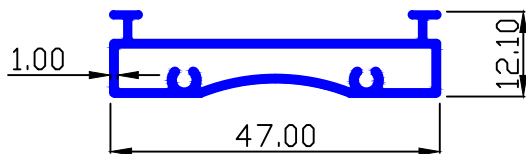

MAAN SEC.-89508

0.220 Kg/Mtr.

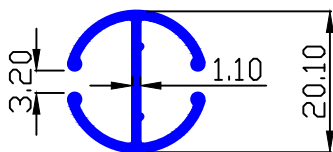



HARD WARE

MAAN SEC.-89593

0.243 Kg/Mtr.

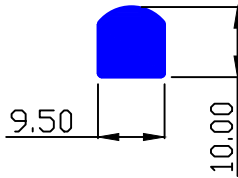

MAAN SEC.-89626

0.830 Kg/Mtr.

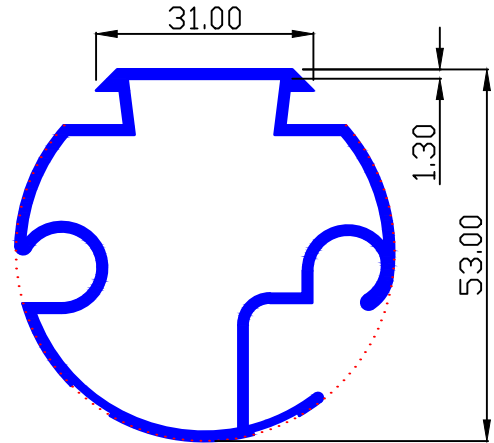

MAAN SEC.-89599

1.720 Kg/Mtr.

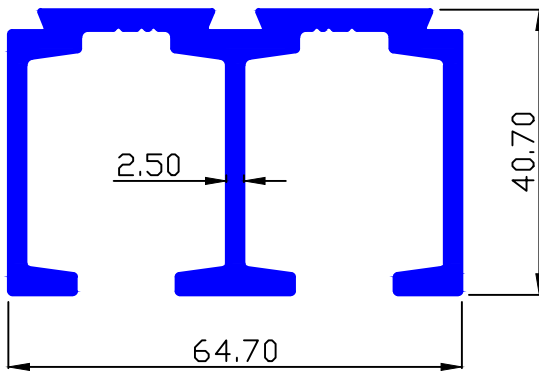

MAAN SEC.-89650

0.505 Kg/Mtr.

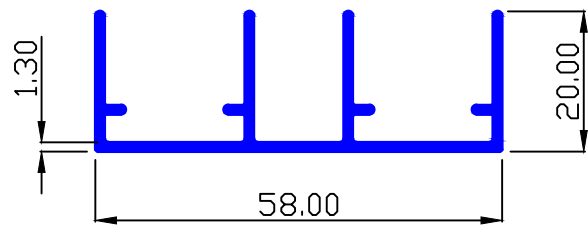

MAAN SEC.-89600

1.449 Kg/Mtr.

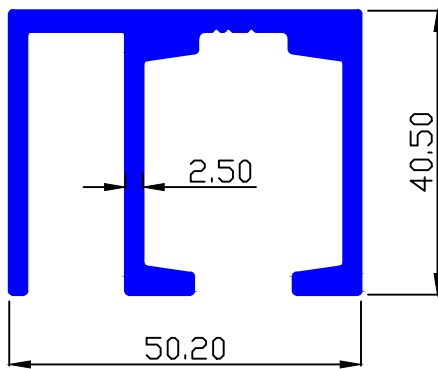

MAAN SEC.-89650/L

0.505 Kg/Mtr.

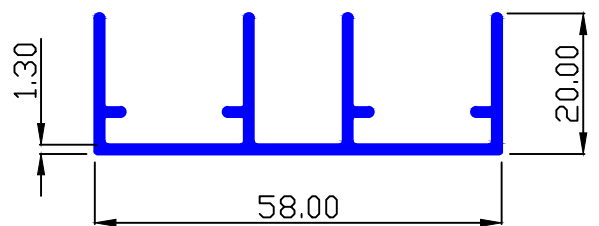

MAAN SEC.-89607

0.214 Kg/Mtr.

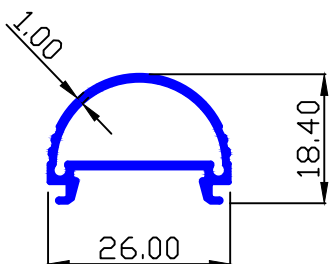

MAAN SEC.-89678

1.301 Kg/Mtr.

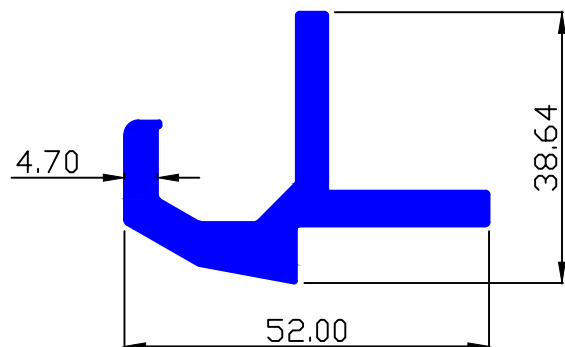



HARD WARE

MAAN SEC.-8863

3.835 Kg/Mtr.

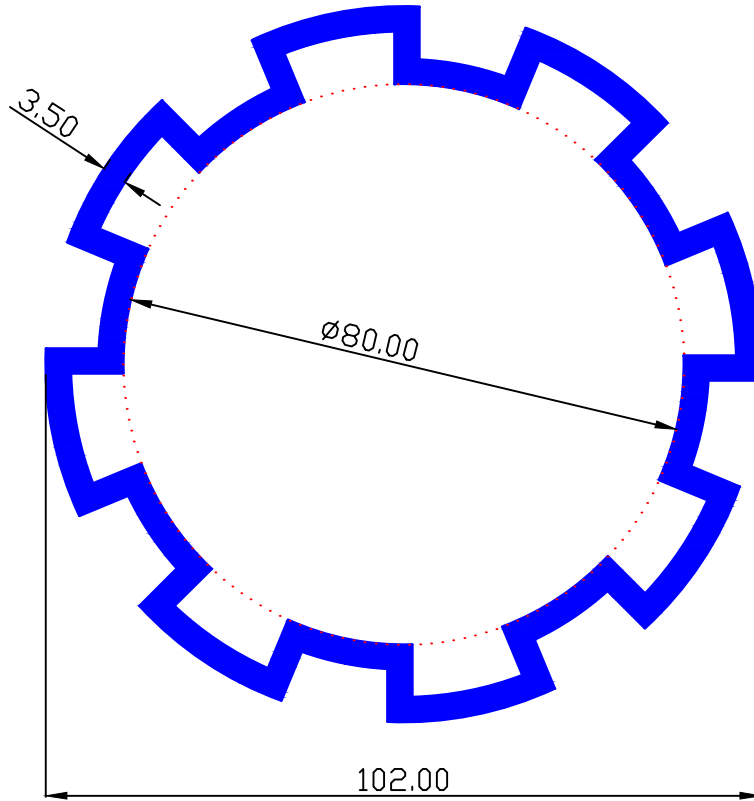

MAAN SEC.-89448

1.210 Kg/Mtr.

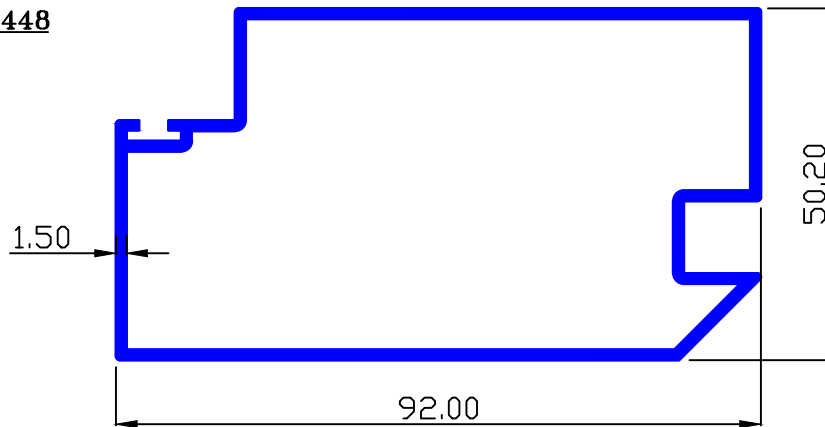

MAAN SEC.-89457

2.814 Kg/Mtr.

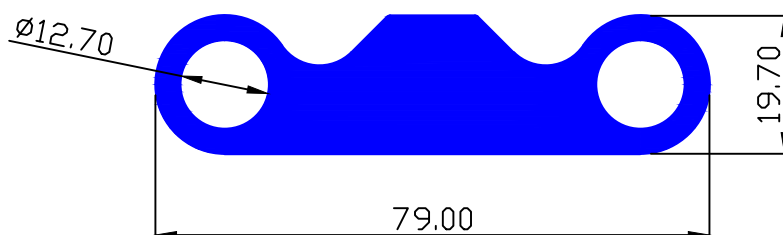



SPECIAL HARD WARE

MAAN SEC.-89765 0.563 Kg/Mtr.

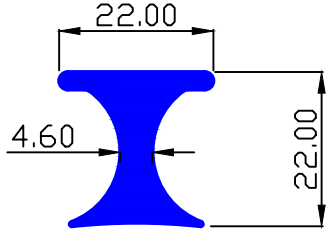

MAAN SEC.-90410 2.128 Kg/Mtr.

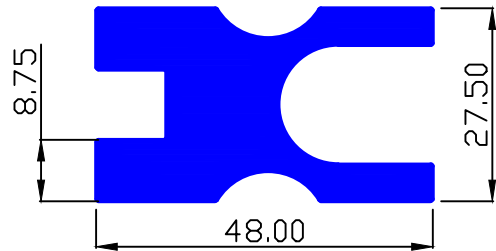

MAAN SEC.-89897 0.548 Kg/Mtr.

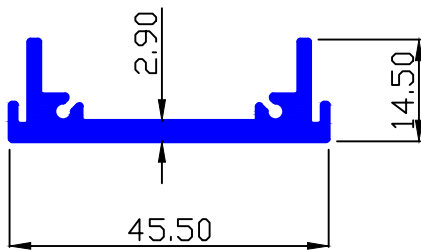

MAAN SEC.-90459 0.650 Kg/Mtr.

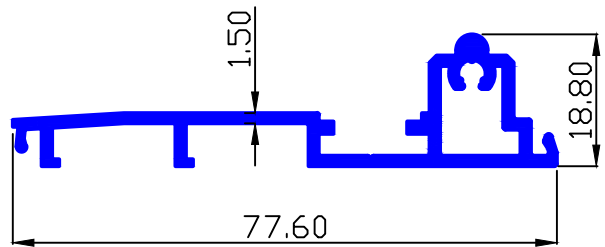

MAAN SEC.-90460 0.192 Kg/Mtr.

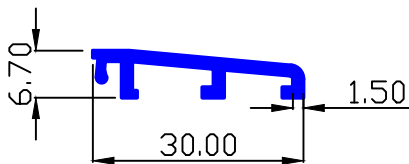

MAAN SEC.-90461 0.057 Kg/Mtr.

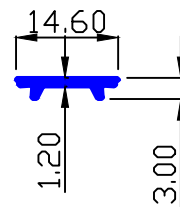

MAAN SEC.-90519 0.873 Kg/Mtr.

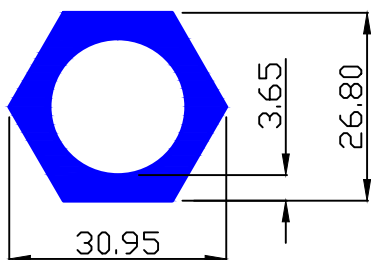

MAAN SEC.-90607 0.141 Kg/Mtr.

